

## The Moderating Role of Retention Factor on The Relationship Between Career Adaptability and Organizational Commitment

Emmanuel. Igbomor<sup>1\*</sup> 

<sup>1</sup> Department of Business Administration, Faculty of Management Sciences, Delta State University, Abraka, Nigeria

\* Corresponding author email address: eigbomor@gmail.com

### Article Info

#### Article type:

Original Research

#### How to cite this article:

Igbomor, E. (IN PRESS). The Moderating Role of Retention Factor on The Relationship Between Career Adaptability and Organizational Commitment. *International Journal of Innovation Management and Organizational Behavior*.

<https://doi.org/10.61838/kman.ijimob.5.x.x>

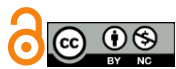

© 2024 the authors. Published by KMAN Publication Inc. (KMANPUB), Ontario, Canada. This is an open access article under the terms of the Creative Commons Attribution-NonCommercial 4.0 International (CC BY-NC 4.0) License.

### ABSTRACT

**Objective:** There is increase in competition among manufacturing companies in Nigeria as a result of rapid changes in the business domain. These changes in the business domain account for the reason why ever companies in the manufacturing sector are interested in having employees that can cope and adapt to changes and also committed to the goals and objective of the organization. This study aims to examine the moderating role of retention factors (compensation) on the relationship between career adaptability and organizational commitment in the manufacturing sector in Nigeria.

**Methodology:** A survey was carried out in this study and one hundred and fourteen (100) questionnaire were administered to the respondents out of which eighty two (82) were fully retrieved and completed. Data obtained from the respondents were analyzed by means of descriptive (Cronbach Alpha, Mean and standard deviation) and inferential (Structural Equation Modeling (SEM) statistical techniques. While hierarchical regression was used to analyze and validate the moderating effect of retention factor on the relationship between career adaptability and organization commitment.

**Findings:** The findings of the study revealed that the effect of career adaptability on organizational commitment is not significant while the effect of career adaptability on retention factor is significant. It was also found that they is no direct effect between retention factor and organizational commitment. Finally, it was confirmed that retention factor has a moderating effect on the link between career adaptability and organizational commitment.

**Conclusion:** Implementation of career development programs and providing opportunities for continuous learning makes top talented employee remain in the organization. And also, employment of retention factors, particularly compensation enhances the commitment of the employees towards the organization.

**Keywords:** career adaptability, retention factor, organizational commitment

## 1 Introduction

An individual's perception of identity and attachment to an organization is known as organizational commitment. Three fundamental traits comprise organizational commitment, (a) a sense of identification with the organization's goals and objectives; (b) a sense of participation in organizational tasks; and (c) a sense of loyalty to the organization (Igbomor & Olisemenogor, 2023; Pranitasari, 2020). Organizational commitment is defined as a strong desire to stay with an organization, a willingness to put in a significant amount of effort on its behalf, and a strong belief in acceptance of the organization's aims and values (Meyer & Allen, 1997). The results of Kuo's (2013) study showed that employee behavior, work features, the organization's socioeconomic environment, and the employees' ambition to stay with the organization are all positively correlated with organizational commitment (Kuo, 2013). According to other study (Sishuwa & Phiri, 2020; Valero, 2019), organizational commitment is primarily the most potent predictor of employee retention since it is based on how people understand and relate to their work. However, a correlate of organizational commitment is career adaptability. The ability to compete and adjust to job changes or the drawbacks of switching careers is referred to as career adaptability (Hamitiaux et al., 2013; Kalafat, 2012; Muchibi et al., 2022; Okorie et al., 2023). Employees with adaptability skills are better able to make informed judgments by keeping an eye out for changes in their work requirements and career path. A person can become open and flexible in their professional life and follow and adapt to changes by being conscious of their own traits and abilities (Akca et al., 2018). Giving employees opportunity for professional growth, job satisfaction, and promotion is one of the most crucial and effective ways to stimulate employee commitment towards the organization (Laddha et al., 2012).

Organizations in the manufacturing sector are more competitive due to technical advancements and globalization. The developments in technology in the workplace have also resulted in apparent and major changes in the requirements of professions. This means that companies that want to survive in this fiercely competitive and dynamic business climate must make sure they retain human resources who can react quickly to changes in their field and workplace and who have a strong sense of belonging to the company. Workers who are highly confident in themselves, adapt well to change, and show a strong sense of loyalty to the company are more likely to

provide positive business results including profitability, efficiency, higher sales, and increased productivity, all of which contribute to better employee retention.

Employee turnover is decreased when workers are prepared to handle unpredictable tasks within their roles, respond to changes in work and working conditions, and identify with the organization's aims and objectives. Employee commitment to the company is higher among those who can adapt to changes in both their professional and work environments (Saviskas & Porfeli, 2012). This may be the rationale behind firms' search for strategies to increase employee commitment to the organization. Employers must, however, determine which retention variables have a greater impact on employee commitment if they hope to see an increase in employee loyalty to the organization (Pathak, 2018). The definition of a job, employment conditions, and job requirements are all changing significantly as a result of technological advancements, globalization, and changes in the business environment. All of these changes make it challenging for employees to plan and make career transitions. Developing adaptability skills is the primary strategy for overcoming these challenges (Akca et al., 2018). Employees, however, need to get ready for the level of professional competence demanded by this dynamic and fiercely competitive corporate climate. One of an organization's most vital and significant resources is its human capital, or its personnel (Adhikari, 2009). Human resources are thought to be the most dynamic when compared to other resources, such as financial, physical, and technological ones (Igbomor, 2023; Pathak, 2018). Managing employee turnover, retention, commitment, and engagement is one of the most difficult problems in human resource management (Igbomor & Ogbuma, 2024; Mahadi et al., 2020)

Low employee commitment poses a threat since it will increase the time and expense the organization must spend on onboarding, training, and preparation of new hires (Mahadi et al., 2020). This indicates that it has a major effect on the organization's financial health. Furthermore, poor employee commitment to the organization lowers productivity, morale, cohesiveness, efficiency, and communication within the organization (Sigler & Adam, 1999) Organizational commitment and the capacity to deal with and adapt to change are critical components of organizational performance in the current business climate, which is marked by intense rivalry, changes, and upheaval (Umamaheswari & Joyce, 2020). The recruitment, training, development, and retention of adequately skilled and

committed personnel are essential to the success and prosperity of an organization (Pathak, 2018). For employees to become more committed and loyal to the organization, they must be able to see a clear career in the organization (Bagga, 2013; Ito & Brotheridge, 2005; Jabaar, 2017). Thus, they will be motivated to stay longer.

Retention factors are actions taken by management to prevent workers from leaving the organization. These actions include: (1) compensating workers for efficiently completing their jobs; (2) fostering cordial working relationships between workers and managers; and (3) preserving a safe and healthy work environment (Cascio, 2003). By influencing how well employees apply their career adaptability to their work and how committed they are to the organization, retention factors (compensation) can influence the link between career adaptability and organizational commitment (Dockel et al., 2006). For example, employees with high degrees of career adaptability may find it difficult to put their skills to use and stick with the organization if they encounter important retention issues like low compensation. Conversely, people with high career adaptability levels who encounter favorable retention factors, like a good work atmosphere, adequate compensation, and chances for advancement, are more likely to be able to take advantage of their flexibility and feel committed to the organization. Career adaptability and retention factors are two examples of external influences that might affect an individual's ability to navigate and adapt to their job (Coetzee & Stoltz, 2015; Mujajati, 2016). Organizations can gain a deeper understanding of their employees' career development and support needs by taking into account the interplay between these elements.

The issue of career adaptability, retention factor and commitment is a concern to researchers and managers, and is a worthy of extra examination. Still, there is a lack of research investigating the moderating role of retention factor on relationship between career adaptability and organizational commitment in Nigeria and in manufacturing industries in particular. In view of the above, this study is therefore, unique as it will help to address this issue and make effort to improve the understanding of the relationship between the three construct under study in Nigeria in general and in manufacturing industries in particular.

## 2 Methods and Materials

To examine the relationship between organizational commitment, career adaptability and retention factors, the

study adopted a survey research design. The reason for this design is to enable the researcher gather information from the respondents using a self-administered questionnaire. A sample size of 100 was drawn from the targeted population of 454 employees at Beta Glass Plc., Ughelli using convenient sampling techniques out of which 82 were valid.

Career adaptability scale developed by Savickas & Porfeli, (2012) consisting of 24 items was used in this study because it measured the specific nature of career adaptability (Savickas & Porfeli, 2012). The scale consists of four dimensions: career concern (measured by 6 items), career control (measured by 6 items), career curiosity (measured by 6 items) and career confidence (measured by 6 items) on a 5-point likert scale ranging from (1) strongly disagreed to (5) strongly agreed.

Retention factor (compensation) was measured by the retention factors measurement scale (RFMS) developed by Dockel, (2003) (Dockel et al., 2006). The retention factors measurement scale developed by Dockel (2003) is designed to assess the factors that influence employee retention within an organization. This scale comprised of six (6) dimensions (subscales) which includes compensation (measured by 11 items), job characteristics (measured by 4 items), career opportunities (measured by 6 items), work-life balance (measured by 4 items), training and development (measured by 6 items) and supervisors support (measured by 6 items) on a 5 point likert scale ranging from (1) strongly disagreed to (5) strongly agreed. However, this present study only used compensation as a dimension of retention factors.

The organizational commitment questionnaire (OCQ) developed by Meyer & Allen, (1997) which is also known as the Three-Component Model of Organizational Commitment was utilized to measure organizational commitment (Meyer & Allen, 1997). This scale measures three components of organizational commitment: affective commitment (measured by 8 items), continuance commitment (measured by 8 items), and normative commitment (measured by 8 items) making it a total of 24 items. The scale was assessed on a 5 point likert scale ranging from (1) strongly disagreed to (5) strongly agreed. This scale was used in this study because it measured every aspect of employees' commitment to the organization. The above measurement scales were proven to be valid and reliable in a study conducted by Jabaar (2017) (Jabaar, 2017). Data obtained from the respondents were analyzed by means of descriptive (Cronbach Alpha, Mean and standard deviation) and inferential (Structural Equation Modeling (SEM) statistical techniques. While hierarchical regression

was used to analyze and validate the moderating effect of retention factor on the relationship between career adaptability and organization commitment. The statistical analysis was carried out via STATA 13.0 Microsoft Statistical software.

**Table 1**

*Mean, Standard Deviation, Minimum and Maximum Values*

Variable(s)	Obs.	Mean	Std. Dev.	Min. Value	Max. Value
Affective Commitment	82	2.9802	.2725	1	5
Continuance Commitment	82	2.7485	.3494	1	5
Normative Commitment	82	3.0107	.2644	1	5
Career Concern	82	4.4512	.4979	1	5
Career Control	82	4.5305	.4751	1	5
Career Curiosity	82	4.5711	.4822	1	5
Career Confidence	82	4.6890	.4827	1	5
Compensation	82	3.0277	.8859	1	5
Ave. Interitem Covariance = .05498		Item in the scale = 13		Cronbach Alpha = .7878	

With regards to the dependent variable (organizational commitment measured by affective, continuance and normative commitment), independent variable (career adaptability proxied by career concern, control, curiosity and confidence), and moderating variable (retention factor proxied by compensation), all variables beat the mean benchmark of 2.50.

The mean and standard deviation values are clear indications that the respondents perceived most of the

### 3 Findings and Results

#### 3.1 Descriptive Statistics

instrument scales as good measures for assessing organizational commitment, career adaptability and retention factor nexus. Again, all variables showed minimal variations in data series as shown in the standard deviation values; implying that respondents perception on the subject are not too dispersed from each other. More so, the minimum and maximum values range between 1-5; suggesting a 5-point Likert scale of the research instrument employed in this study.

**Table 2**

*Reliability Results*

Variables	Cronbach's Alpha
Organizational Commitment	0.61
Retention Factor	0.52
Career Adaptability	0.92
<i>Composite Cronbach Alpha Value</i>	<i>0.78</i>

Cronbach's alpha values (Table 2) were all above 0.5; the composite reliability for organizational commitment, career adaptability and retention factor (0.78) also exceeded minimum threshold, which is considered reliable as recommended by Fornell and Larcker (1981); thus, the research instrument is considered reliable for the investigation (Fornell & Larcker, 1981).

#### 3.2 Structural Equation Modeling (SEM) Results

Table 3 revealed that the direct effects of retention factor (compensation – *rfcompen*) and all organizational commitment metrics (affective - *orgcafcmm*, continuance –

*orgccontcommand* normative – *orgnormcomm*) are insignificant as indicated in the p-value; thus, there is no direct effect between organizational commitment and retention factor. On the other hand, we found direct effects of retention factor and career adaptability (career concern - *cacareerconc*, control - *cacareercont*, curiosity – *cacareercur*, and confidence – *cacareerconf*), given that the p-values of career adaptability metrics are less than 0.05; consequently, a direct effect ensue between career adaptability and retention factor.

Furthermore, no indirect effect was established between organizational commitment and career adaptability metrics,

as moderated by retention factor. Overall, the SEM result shows that the relationship between career adaptability metrics and organizational commitment is not supported.

Also, the relationship between organizational commitment and retention factor is not supported while the relationship between career adaptability and retention factor is supported.

Figure 1

Results of the Model

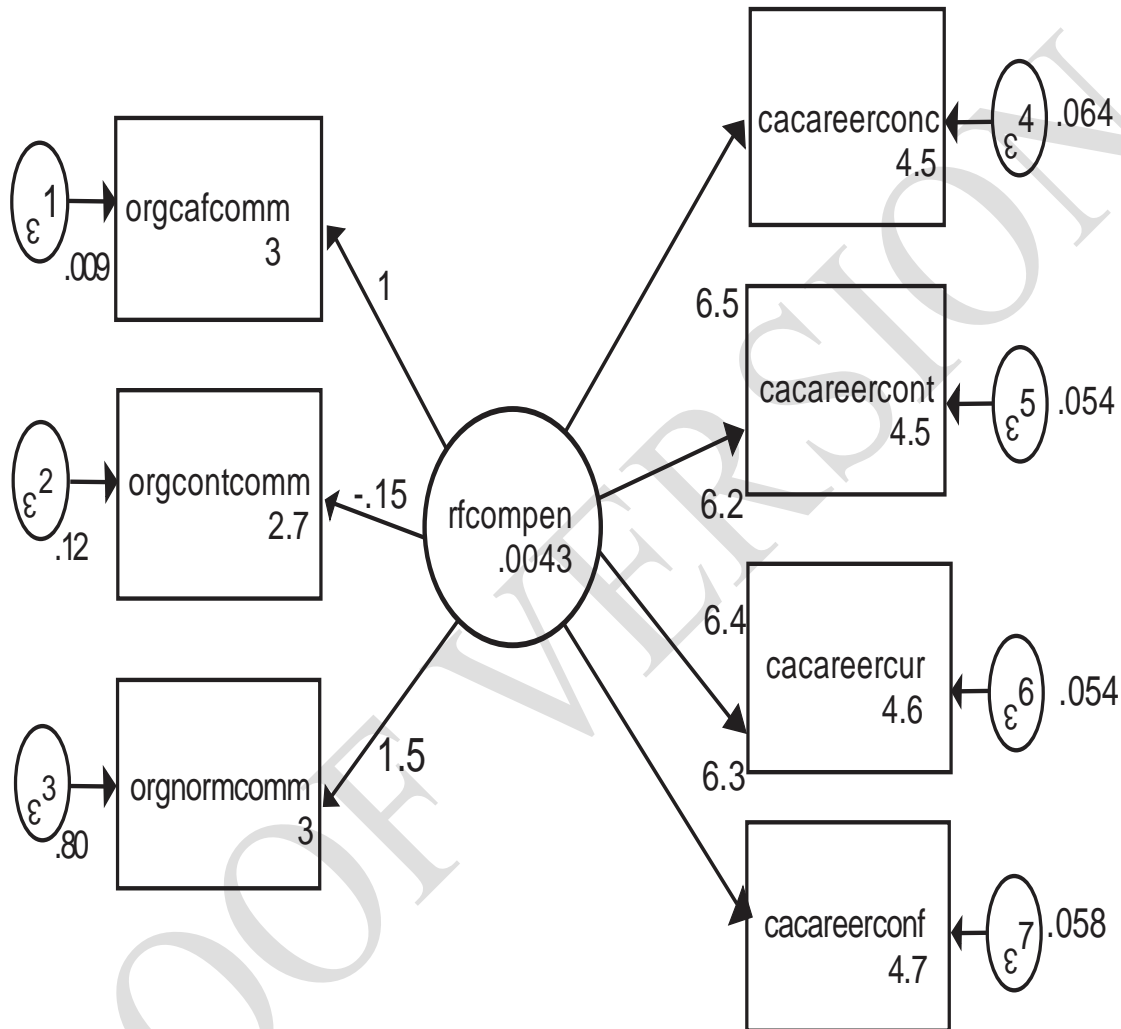

Table 3

Model's Standardized Regression Weights (SRW), Z-Scores and P-Values

Path	SRW	Z-Scores	P-Values
Direct Effects of Integrative Model			
Orgcafomm			
rfcompen			
orgccontcomm			
rfcompen	.61510	-0.25	.801
orgnormcomm			
rfcompen	.78219	1.87	.062
cacareeronc			
rfcompen	3.0058	2.15	.032
careercont			
rfcompen	2.8965	2.15	.031
cacareercur			

rfcompen	2.9965	2.12	.034
cacareeronf			
rfcompen	2.9544	2.13	.033
Indirect Effects of Integrative Model			
Orgcafomm			
rfcompen			
orgccntcomm			
rfcompen	No Path		
orgnormcomm			
rfcompen	No Path		
cacareeronc			
rfcompen	No Path		
careercont			
rfcompen	No Path		
cacareercur			
rfcompen	No Path		
cacareeronf			
rfcompen	No Path		
Total Effects of Integrative Model			
Orgcafomm			
rfcompen			
orgccntcomm			
rfcompen	.61510	-0.25	.801
orgnormcomm			
rfcompen	.78219	1.87	.062
cacareeronc			
rfcompen	3.0058	2.15	.032
careercont			
rfcompen	2.8965	2.15	.031
cacareercur			
rfcompen	2.9965	2.12	.034
cacareeronf			
rfcompen	2.9544	2.13	.033

\*p<0.05; \*\*p<0.01; \*\*\*p<0.001; \*indicates hypothesis was supported

### 3.3 Goodness of Fit Tests

We applied SEM fit indicators to test the validity of the variables (organizational commitment, career adaptability and retention factor). The result showed that the measurement models provide absolute fit to data ( $X^2/df = 60.73$ ,  $GFI = 0.925$ ,  $AGFI = 0.767$ ,  $CFI = 0.845$ ,  $RMR =$

0.114, and  $RMSEA = 0.255$ ). More importantly, the measurement models (GFI, AGFI and CFI) surpass the advocated threshold of 0.70. On the other hand, RMSEA and RMR were below the threshold of 0.8. An indication that the approach used for modeling organizational commitment, career adaptability, moderated by retention factor fits properly.

**Table 4**

*Fit Indicators of Organizational Commitment, Career Adaptability and Retention Factor*

Fit Indicator(s)	Coefficients	Remark
Goodness of Fit Statistics (GFI)	0.925	Significant
Adjusted Goodness of Fit Statistic (AGFI)	0.767	Significant
Comparative Fit Index (CFI)	0.845	Significant
Root Mean Square Residual (RMR)	0.114	Significant
Root Mean Square Error of Approximation (RMSEA)	0.255	Significant
Chi-Square	60.73	

Under LR, a repeat of the model  $\chi^2$  test showed that the model fits as well as the saturated model. Similarly, the baseline versus saturated comparison implies that the

baseline model fits as well as the saturated model; as they were all significant at 5% level. The AIC and BIC were used to compare the fit of the dissimilar models.

According to Akaike (1987), smaller values signal a better fit (Akaike, 1987). The model for organizational commitment, career adaptability and retention factor has

AIC and BIC values of 322.889 and 373.4301; thus, AIC has the smallest value, indicating that AIC best fits the model

**Table 5**

*Likelihood Ratio (LR), Akaike's Information Criterion (AIC) and Bayesian Information Criterion (BIC) Results*

Fit Statistics)	Value	Description
Likelihood Ratio (LR)		
Chi2_ms (14)	60.735	Model vs. Saturated
p > chi2	0.000	
Chi2_bs(1)	322.462	Baseline vs. Saturated
p > chi2	0.000	
Information Criteria		
AIC	322.889	Akaike's Information Criterion
BIC	373.4301	Bayesian Information Criterion

Presented in Table 6 is stability result of simultaneous equation systems (SRSES) for modeling organizational commitment, career adaptability and retention factor. SRSES establishes whether the model parameters are such that the model would blow up if it were operated repeatedly.

A stability index of less than one (1) implies that reported estimates yield a stable model (Acock, 2013; Wheaton et al., 1977). The stability index is zero (0), indicating that all the eigenvalues lie within the unit circle and SEM satisfies stability condition.

**Table 6**

*Stability Result of Simultaneous Equation Systems (SRSES)*

Eigenvalue Stability Condition (ESC)	Modulus
0	0
0	0

### 3.4 Validating the Moderating Effects

The moderating effect of retention factor in the relationship between organizational commitment and career adaptability is presented in Table 7. The regression model revealed that the product of career adaptability and retention factor increased the coefficient of determination  $R^2$  to 0.894, resulting in a variation ( $\Delta R^2$ ) of 0.886 in organizational commitment.

More so, the regression coefficient is ( $\beta = 0.728$ ,  $p < 0.001$ ), indicating that retention factor has a moderating effect on the link between organizational commitment and career adaptability; this confirms the hypothesis of our study of a moderating effect of retention factor in the relationship between organizational commitment and career adaptability. Impliedly, when organizations employ retention factors, particularly compensation, organizational commitment is heightened.

**Table 7**

*Hierarchical Regression Results*

Variables	Model
Step 1: Independent Variable	0.047
Step 2: Moderator Variable	0.210
Step 3: Interaction among Variables	0.728***
$R^2$	0.894
$\Delta R^2$	0.886
F	47.23***

\* $p < 0.05$ ; \*\* $p < 0.01$ ; \*\*\* $p < 0.001$

#### 4 Discussion and Conclusion

The objective of the study is to examine the relationship between career adaptability, retention factors and organizational commitment in the manufacturing sector in Nigeria. Analysis of the data collected from all the participants of the study revealed that there is insignificant effect of career adaptability on organizational commitment in hypothesis 1. This led to the rejection of the alternative hypothesis and acceptance of the null hypothesis. The implication is that the effect of career adaptability does not affect the organizational commitment of employees in the manufacturing sector in Nigeria. This implies that employee's ability to respond positively and actively to unpredictable changes in their career as well as in the workplace has no effect on their commitment towards the organization. This could happen if employees put their personal professional growth ahead of their commitment to the company. High adaptability makes an employee more likely to look for new alternatives and, when they feel that their current employer is no longer meeting their goals for professional growth, they start thinking about quitting. Their ongoing pursuit of opportunities to succeed outside of their workplace may cause them to become less committed to their current organization, which will result in decreased organizational commitment levels. Moreover, employees who are highly adaptable in their careers might be less likely to devote time and energy to establish strong relationships with coworkers and creating a feeling of belonging within the organization. Their emotional tie to the organization may be further weakened by this lack of social connection and sense of belonging, which could lead to a decline in organizational commitment. A diminished sense of commitment might result from employees who are continuously looking for new challenges and opportunities in their careers failing to recognize the long-term advantages of sticking with a particular organization. These findings disagreed with the findings of (Ito & Brotheridge, 2005; Jabaar, 2017) which finding showed that career adaptability is positively associated with organizational commitment.

On the other hand, there is a direct effect of career adaptability on retention factor as stated in hypothesis 2. Hence, the alternative hypothesis is accepted. This implies that employees with high career adaptability shows high levels of retention factor and are willing to remain in the organization. Employees are more inclined to stick with an organization over a lengthy period if they believe they have

the resources and assistance that they require to adapt and succeed in their roles. This ability to achieve success and adjust to changes in their professional life can result in increased job engagement, which is crucial for encouraging employee retention. Employee retention may rise when workers feel more fulfilled and have a feeling of purpose in their work and when they are able to manage their career paths within the organization. This finding is supported by the findings of (Coetzee & Stoltz, 2015; Mujajati, 2016) which revealed that the higher the career adaptability of an individual, the more likely that such an individual will have a high level of retention factors. Employees who are adaptable to changes in their career and their workplace are satisfied with the retention factors provided by their organization and choose to remain in the organization.

Furthermore, there is no direct effect between retention factor and organizational commitment in hypothesis 3. This led to the rejection of the alternative hypothesis and the acceptance of the null hypothesis. In other words, the relationship between retention factor and organizational commitment is not supported. Although studies have suggested that providing attractive retention factors—compensation in particular—can boost employees' commitment to the organization, the current study did not find a direct correlation between these dimensions. This lack of support suggests that other elements or characteristics might have a bigger impact on how committed employees are to their organization. One possible reason for the absence of evidence supporting the association between organizational commitment and retention factors (compensation) could be the complexity of individual motivations and attitudes toward their jobs. While retention factors (compensation in particular) play a significant role in keeping employees on board, they may not be the only criteria that determine employee commitment to the organization. Employee work satisfaction, corporate image, leadership/management style, and personal beliefs are some of the additional factors that could have a big impact on how committed an employee is to his or her employer. This implies that retention factors by themselves are not sufficient to fully explain the complex concept of organizational commitment. This finding disagreed with the findings of (Pathak, 2018; Sishuwa & Phiri, 2020; Umamaheswari & Joyce, 2020) which findings established that positive relationship exist between retention factors and organizational commitment.

Finally, the result of the study indicated that retention factor has a moderating effect in the relationship between



career adaptability and organizational commitment as stated in hypothesis 4. Hence, the alternative hypothesis is accepted. The implication is that when organizations employ retention factors, particularly compensation, organizational commitment is heightened. Employees with high career adaptability may be more inclined to look for new alternatives and even contemplate leaving the company if they believe their career goals are not being realized. Strong retention factors in this case, including attractive compensation, might serve as inducements for these workers to continue staying and show their commitment to the organization. This is in line with the finding of Dockel et al., (2006) (Dockel et al., 2006).

This research was carried out to examine the relationship between career adaptability, retention factors and organizational commitment. However, the study's sample size was relatively small. Therefore, more research on the relationship between the three constructs under consideration should be done using a bigger sample size and population. This is because inaccurate inferential statistics may result from making conclusions based on limited populations and samples. It is challenging to generalize the findings to a larger population when the sample is relatively small. As a result, it may be more difficult to draw significant conclusions from the study and its practical consequences may be limited. Additionally, this study focused on the manufacturing sector in Nigeria. Further studies can be done in other sectors of the economy, such as industrial goods business organizations, health sector and educational sector.

Many employees have undergone difficult career transitions and moved away from traditional careers in favor of new mindsets, attitudes, and ways of being and doing things, which are known as boundary-less and protean careers, as a result of the rapidly evolving business environment brought about by technological advancements. Organizations are facing a challenge in maintaining talented individuals through the implementation of effective retention policies, as a result of the dynamic shift from old to new mindsets. Organizations must, however, provide career development options that will increase the length of time that highly talented employees stay with the organization and strengthen their sense of commitment. In order to attract and maintain highly skilled and productive employees, organizations must design strong and appealing career development programs, continuous learning opportunities, and productivity training. This will help them retain such unique and scarce talent. Additionally,

management needs to do a better job of fostering an environment at work that motivates workers to be committed to the organization and to remain there. In addition, it is recommended that Management utilize retention factors, specifically compensation, to strengthen employee commitment to the organization. This is due to the fact that compensation is a key factor in determining an employee's loyalty to their employer. An employee's commitment to the organization may increase as they are happy with their salary.

The need for more investigation into the underlying mechanisms that impact the linkages between organizational commitment, career adaptability, and retention factors is one of the implications for future research in these areas. Researchers could investigate how individual differences—such as motivation, self-efficacy, and personality traits— affect how people interact with their organizations and traverse their careers. Gaining insight into the interplay between these human qualities and career adaptability and retention factors may help identify the factors that motivate organizational commitment. Future studies may also examine how organizational commitment is affected by changes in work environments and technology improvements. Artificial intelligence and remote employment have caused a rapid evolution in the nature of jobs and organizational relationships. Examining the impact of these external influences on employees' views of retention factors, career adaptability, and commitment to their organizations may provide insights for organizations looking to adjust to a workforce that is changing swiftly.

### Authors' Contributions

All authors have contributed significantly to the research process and the development of the manuscript.

### Declaration

None.

### Transparency Statement

Data are available for research purposes upon reasonable request to the corresponding author.

### Acknowledgments

We would like to express our gratitude to all individuals helped us to do the project.

## Declaration of Interest

The authors report no conflict of interest.

## Funding

According to the authors, this article has no financial support.

## Ethical Considerations

In this research, ethical standards including obtaining informed consent, ensuring privacy and confidentiality were observed.

## References

- Acock, A. C. (2013). *Discovering Structural Equation Modeling Using STATA*. STATA Press. <https://www.stata.com/bookstore/discovering-structural-equation-modeling-using-stata/>
- Adhikari, D. R. (2009). *Human Resource Management*. Budha Academic Enterprises PVT. Ltd. [https://www.researchgate.net/publication/374019829\\_Human\\_resource\\_management\\_practices\\_in\\_Nepalese\\_organization\\_s\\_Some\\_observations](https://www.researchgate.net/publication/374019829_Human_resource_management_practices_in_Nepalese_organization_s_Some_observations)
- Akaike, H. (1987). Factor Analysis and AIC. *Psychometrika*, 52, 317-332. <https://doi.org/10.1007/BF02294359>
- Akca, Y., Ozer, G., & Kalaycioglu, E. (2018). Impact of Career Adaptability on Employee Performance. *International Journal of Business and Management Invention*, 7(11), 24-28. [https://www.ijbmi.org/papers/Vol\(7\)11/Version-2/E0711022428.pdf](https://www.ijbmi.org/papers/Vol(7)11/Version-2/E0711022428.pdf)
- Bagga, G. (2013). How to Keep the Talent You Have Got. *Human Resource Management International Digest*, 21(1), 3-4. <https://doi.org/10.1108/09670731311296401>
- Cascio, W. F. (2003). *Managing Human Resource*. McGraw-Hill. [https://books.google.com/books/about/Managing\\_Human\\_Resources.html?id=iUVfQgAACAAJ](https://books.google.com/books/about/Managing_Human_Resources.html?id=iUVfQgAACAAJ)
- Coetzee, M., & Stoltz, E. (2015). Employees' Satisfaction with Retention Factors: Exploring the Role of Career Adaptability. *Journal of Vocational Behavior*, 89, 83-91. <https://doi.org/10.1016/j.jvb.2015.04.012>
- Dockel, A., Basson, J. S., & Coetzee, M. (2006). The Effect of Retention Factors on Organizational Commitment: An Investigation of High Technology Employees. *South African Journal of Human Resource Management*, 4(2), 20-28. <https://doi.org/10.4102/sajhrm.v4i2.91>
- Fornell, C., & Larcker, D. F. (1981). Evaluating Structural Equation Models with Unobservable Variables and Measurement Error. *Journal of Marketing Research*, 18(1), 39-50. <https://doi.org/10.1177/002224378101800104>
- Hamitiaux, A., Houssemand, C., & Vrignaud, P. (2013). Individual and Career Adaptability: Comparing Models and Measures. *Journal of Vocational Behavior*, 83(2), 130-141. <https://doi.org/10.1016/j.jvb.2013.03.006>
- Igbomor, E. (2023). The Relationship Between Strategic Human Resource Management Practices and Employee Performance: The Moderating Role of Information Communication Technology (ICT) Usage. *International Journal of Management Studies and Social Science Research*, 5(5), 294-307. <https://doi.org/10.56293/IJMSSSR.2022.4726>
- Igbomor, E., & Ogbuma, S. M. (2024). An Empirical Evidence of the Effect of Organizational Commitment on Employee Job Performance. *International Journal of Research Publication and Reviews*, 5(1), 1941-1947. <https://ijrpr.com/uploads/V5ISSUE1/IJRPR21806.pdf>
- Igbomor, E., & Olisemenogor, H. C. (2023). The Nexus Between Employee Assistance Programs and Organizational Commitment. *International Journal of Research and Innovation in Social Science (IJRISS)*, 8(12), 1-13. <https://doi.org/10.47772/IJRISS.2023.7012001>
- Ito, J. K., & Brotheridge, C. M. (2005). Does Supporting Employee Career Adaptability Lead to Commitment Turnover, or Both? *Human Resources Management*, 44, 5-19. <https://doi.org/10.1002/hrm.20037>
- Jabaar, R. (2017). *The Relationship Between Organizational Commitment, Career Adaptability and Retention Factors Within the Retail Sector in the Western Cape* Master Thesis]. <https://core.ac.uk/download/pdf/95521708.pdf>
- Kalafat, T. (2012). Kariyer Geleceği Ölçeği (KARGEL): Türk Örnekleme İçin Psikometrik Özelliklerinin İncelenmesi [Career Futures Inventory (CFI): The Examination of Psychometric Properties in Turkish Sample]. *Turkish Psychological Counseling and Guidance Journal*, 4(38), 169-179. <https://doi.org/10.17066/pdrd.43967>
- Kuo, Y. (2013). Organizational Commitment in an Intense Competition Environment. *Industrial Management and Data System*, 113(1), 39-56. <https://doi.org/10.1108/02635571311289656>
- Laddha, A., Singh, R., Gabbad, H., & Gidwani, G. D. (2012). Employee Retention: An Art to Reduce Turnover. *International Journal of Management Research and Review*, 2(3), 453-458. <https://www.proquest.com/scholarly-journals/employee-retention-art-reduce-turnover/docview/1419632188/se-2>
- Mahadi, N., Woo, N. M. F., Baskaran, S., & Yaakop, A. Y. (2020). Determinant Factors for Employee Retention: Should I Stay? *International Journal of Academic Research in Business and Social Sciences*, 10(4), 201-213. <https://doi.org/10.6007/IJARBS/v10-i4/7120>
- Meyer, J. P., & Allen, N. J. (1997). *Commitment in the Workplace: Theory, Research and Application*. Sage. <https://doi.org/10.4135/9781452231556>
- Muchibi, W. M., Mutua, S. M., & Juma, D. (2022). Influence of career development on employee engagement in the public health sector in Kenya. *International Academic Journal of Human Resource and Business Administration*, 4(1), 297-327. [https://iajournals.org/articles/iajhrba\\_v4\\_i1\\_297\\_327.pdf](https://iajournals.org/articles/iajhrba_v4_i1_297_327.pdf)
- Mujajati, E. (2016). *Investigating the relationship between career adaptability, employability attributes, and retention factors of employees in selected 21st century recruitment agencies* [https://www.researchgate.net/publication/341110972\\_Investigating\\_the\\_relationship\\_between\\_career\\_adaptability\\_employability\\_attributes\\_and\\_retention\\_factors\\_of\\_employees\\_in\\_selected\\_21st\\_century\\_recruitment\\_agencies](https://www.researchgate.net/publication/341110972_Investigating_the_relationship_between_career_adaptability_employability_attributes_and_retention_factors_of_employees_in_selected_21st_century_recruitment_agencies)
- Okorie, C. O., Nwankwo, F. M., Iwuala, H. O., Agudiegwu, M. O., Nnadi, S. O., Nkwede, J. O., Nwachukwu, C. K., Arua, C. C., Osuebi, K. T., Ejem, E. N., & Chigbata, E. S. (2023). Core self-evaluation and job embeddedness: influences on career adaptability and work engagement in Nigeria public sector employees. *Journal of Psychology in Africa*, 3(2), 150-157. <https://doi.org/10.1080/14330237.2023.2182011>
- Pathak, G. P. (2018). Influence of Retention factors on employees commitment: evidence from Nepalese Commercial Banks. *International Journal of Innovative Research in Science, Engineering and Technology*, 7031-7039.

- [http://www.ijirset.com/upload/2018/june/45\\_5\\_Influence\\_NEW.pdf](http://www.ijirset.com/upload/2018/june/45_5_Influence_NEW.pdf)
- Pranitasari, D. (2020). The influence of Effective Leadership and Organizational Trust to Teacher's work motivation and Organizational Commitment. *Media Ekonomi dan Manajemen*, 35(1), 75-91. <https://doi.org/10.24856/mem.v35i1.1257>
- Saviskas, M. L., & Porfeli, E. J. (2012). Career Adaptability Scale: Construction, Reliability and Measurement Equivalence Across 13 Countries. *Journal of Vocational Behavior*, 80, 661-673. <https://doi.org/10.1016/j.jvb.2012.01.011>
- Sigler, K. W., & Adam, J. S. (1999). Difference Between Stayers and Leaders Among Part-Time Workers. *Journal of Management Issues*, 11, 110-125. <https://digitalcommons.kennesaw.edu/cgi/viewcontent.cgi?article=3406&context=facpubs>
- Sishuwa, Y., & Phiri, J. (2020). Factors Influencing Employee Retention in the Transport and Logistics Industry. *Open Journal of Social Sciences*, 8, 145-160. <https://doi.org/10.4236/jss.2020.86013>
- Umamaheswari, S., & Joyce, S. (2020). Antecedents and Consequence of Organizational Commitment Among Employees of Ceramic Industries in India. *Journal of Critical Reviews*, 7(6), 20-22. <https://doi.org/10.31838/jcr.07.06.05>
- Valero, J. P. (2019). *The Effect of Training and Development on Organizational Commitment as Key Elements to Retain Talent in Business Organization* <https://repositorio.comillas.edu/xmlui/handle/11531/27788>
- Wheaton, B., Muthen, B., Alwin, D. F., & Summers, G. F. (1977). *Assessing Reliability and Stability in Panel Models* *Sociological Methodology* 1977. Jossey-Bass. <https://doi.org/10.2307/270754>